

485 Backhoe

For skid-steer loaders.

FEATURES:

- Full 180° swing rotation with equal power in both directions
- Built from 10 gauge high-strength 100ksi steel to minimize weight and increase strength for durability
- Highback seat is adjustable vertically as well as forward and aft
- Standard swing speed control is standard and allows the operator to adjust swing speed
- 2 year limited warranty



PALADIN LIGHT CONSTRUCTION



485 Backhoe

FEATURES

- Circuit relief valve protected while allowing smooth operation, SAE float detent in boom circuit
- Fully engineered and tested in rigorous real-life conditions
- Cushioned swing cylinders for smooth operation
- Inline filter and check valve insures longer valve life and less maintenance
- Replaceable hardened bushings in all pivot points decreases maintenance costs
- Stress proof pins provide higher strength and increased wear resistance
- High strength steel and ductile iron castings in high stress areas

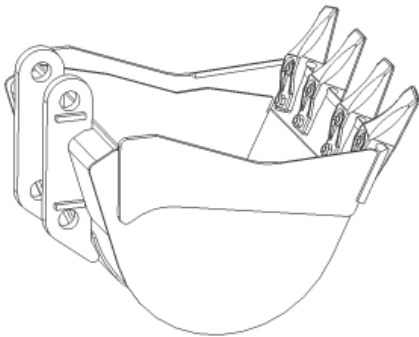

Buckets & Capacities

| bucket size | heaped cap. ft. ³ | weight lbs. | number of teeth* |
|-------------|------------------------------|-------------|------------------|
| 10" | .92 | 80 | 3 |
| 12" | 1.20 | 85 | 3 |
| 16" | 1.86 | 102 | 4 |
| 18" | 2.14 | 109 | 4 |
| 24" | 3.10 | 130 | 5 |

* buckets available without teeth

Specifications

Transport

| | |
|---|----------|
| A. Transport height (with boom retracted) | 81" |
| Transport width (with stabilizers up) | 51" |
| B. Ground clearance | 10" |
| C. Overall length | 83" |
| Boom pivot height | 12" |
| Operating weight with 12" bucket | 1010 lbs |
| Weight without bucket | 665 lbs |

Operational

| | |
|--|----------|
| D. Digging depth (maximum) | 101" |
| E. Digging depth (2' flat bottom) | 100" |
| F. Digging depth (8' flat bottom) | 52" |
| G. Overall operating height - fully raised | 121" |
| H. Loading height | 63" |
| J. Loading reach | 58" |
| K. Reach from swing post | 127" |
| L. Bucket rotation | 180° |
| Swing arc | 180° |
| Stabilizer spread operating position | 90" |
| Stabilizer down below grade | 10" |
| System relief valve setting | 2750 PSI |
| Digging force - bucket cylinder | 2895 lbs |
| Digging force - dipper cylinder | |

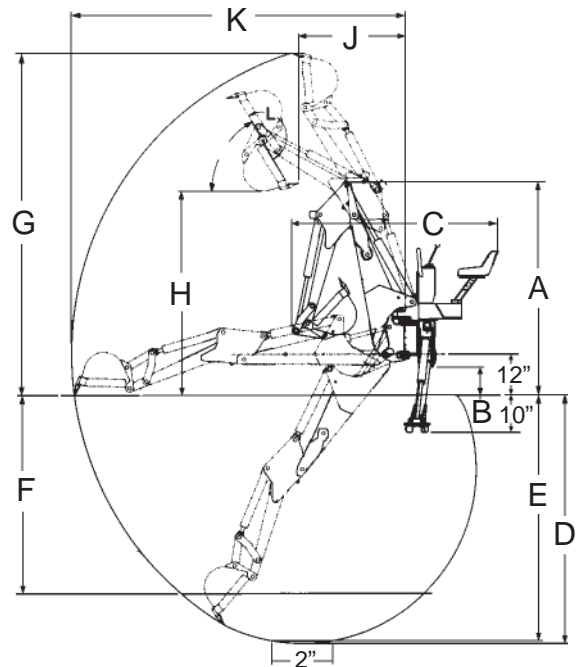

Specifications and design are subject to change without notice and without liability, therefore, whenever applicable specifications are in accordance with SAE standards.

PH: (800) 922-2981

FX: (563) 922-2700

P.O. Box 266

Delhi, IA 52223-0266

United States of America

www.paladinbrands.com

 BRADCO

 FFC

 HARLEY

 MAJOR

 McMILLEN

 SWEEPSTER

PALADIN LIGHT CONSTRUCTION