

4-IN-1 Multi-Purpose Buckets

For skid-steer loaders

FEATURES:

- 66" & 72" Utility Grade widths available and 72", 78" & 84" Construction Grade widths available
- With or without teeth available
- Functions as a loader bucket, clam, dozer, scraper and bottom dump bucket
- Heavy duty hinges and pins to distribute load
- Hose Saver Spring Kit is standard
- Optional spill guard, cylinder covers, tooth bars and bolt on edges
- 1 year limited warranty

 **BRADCO**

 **FFC**

 **HARLEY**

 **THE MAJOR**

 **McMILLEN**

 **SWEEPSTER**

PALADIN LIGHT CONSTRUCTION



Construction Grade
Shown with optional side cutters and spill guard



Utility Grade

4-IN-1 Multi-Purpose Buckets

| Specifications | Utility Grade | | Construction Grade | | |
|--------------------------|---------------|--------|--------------------|--------|--------|
| | MP66 | MP72 | MP72 | MP78 | MP84 |
| Order Codes (w/o teeth) | 108018 | 108020 | 108022 | 108024 | 108026 |
| Order Codes (with teeth) | 108019 | 108021 | 108023 | 108025 | 108027 |
| A. Width (overall) | 66.96" | 72.96" | 72.75" | 78.75" | 84.75" |
| B. Height (overall) | 27.32" | 27.32" | 27.57" | 27.57" | 27.57" |
| C. Length (overall) | 34.47" | 34.47" | 38.13" | 38.13" | 38.13" |
| D. Clam Length | 23.06" | 23.06" | 26.67" | 26.67" | 26.67" |
| E. Back Blade Length | 12.36" | 12.36" | 12.41" | 12.41" | 12.41" |
| F. Clamp Opening | 34.64" | 34.64" | 34.79" | 34.79" | 37.79" |
| Operating Pressure (PSI) | 2250 | 2250 | 2250 | 2250 | 2250 |
| Clamping Force (lbs) | 2354 | 2354 | 4011 | 4011 | 4011 |
| Weight | 620 | 655 | 900 | 935 | 975 |
| Heaped Capacity (cu/ft) | 15.76 | 17.23 | 19.99 | 21.69 | 23.40 |
| Cylinder Specifications | | | | | |
| Bore | 2.00" | 2.00" | 2.50" | 2.50" | 2.50" |
| Stroke | 7.50" | 7.50" | 7.50" | 7.50" | 7.50" |
| Rod Diameter | 1.12" | 1.12" | 1.25" | 1.25" | 1.25" |

Optional spill guard, cylinder covers, tooth bars and bolt-on edges available.

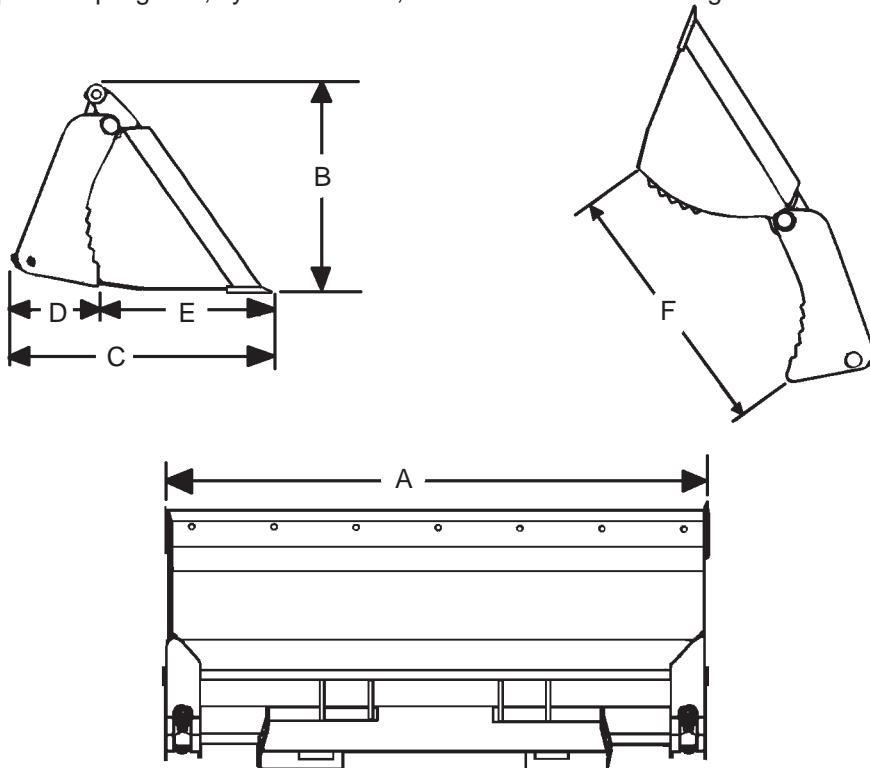

Specifications and design are subject to change without notice and without liability, therefore, whenever applicable specifications are in accordance with SAE standards.

FEATURES:

UTILITY & CONSTRUCTION GRADES

- Conventional or bottom dump buckets allows the operator to dump into high side board trucks
- Long-floor design improves cutting edge visibility, for maximum accuracy when grading
- Constructed of high tensile material for reduced weight and higher strength
- Optional removable spill plate for improved visibility

CONSTRUCTION GRADE

- Dual check valve
- Spherical bushings on cylinder ends
- 1" x 6" cutter edge on front of clam and 3/4" x 6" high carbon edge on rear of clam
- Optional side cutters
- Optional bolt-on tooth bars
- Optional bolt-on tooth bar that will fit with bolt on edge

PH: (800) 922-2981
FX: (563) 922-2700

P.O. Box 266
Delhi, IA 52223-0266
United States of America

www.paladinbrands.com

B - 4-in-1 Bucket 0705-1

